

MOORING CAPSTAN CH-E

Electric mooring capstan CH-E.

Drive: inside wrapping head

Driven mode: electric

Voltage: 220 and 380 V

The mooring capstan could be customized by request.

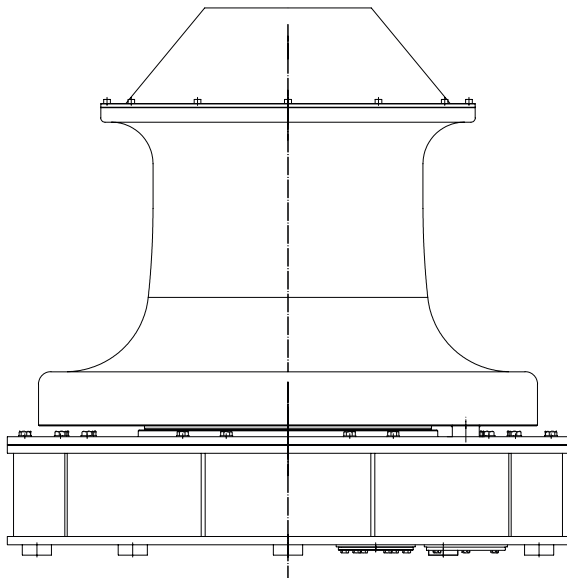

Model	CH-20E	CH-30E	CH-50E	CH-80E
1. Working load on the wrapping head, kN	20	30	50	80
2. Nominal mooring speed:				
nominal, m/sec	0,26-0,27	0,23-0,27	0,23-0,27	0,20-0,25
min, m/sec		0,10-0,17	0,10-0,12	0,08-0,12
max, m/sec	0,56-0,59	0,40-0,44	0,45-0,55	0,42-0,55
3. Mooring rope (max)				
Steel rope, diameter, mm	19	23	26,5	30,5
Synthetic, circ, mm	90	115	150	175
4. Working mode, min	30 / 30	30 / 30 / 10	30 / 30 / 10	30 / 30 / 10
5. Power, kW	12 / 8	15 / 11 / 7	18,5 / 15 / 10	25 / 25 / 18